

edp[®] Dual One Tonne Bag Filler

e-as^y as...edp



- Potatoes - Onions -

With 60 years in the Fruit and Vegetables industry we have the expertise and experience to give you, our valued customer, the best and most reliable equipment economically possible



e-as^y as..



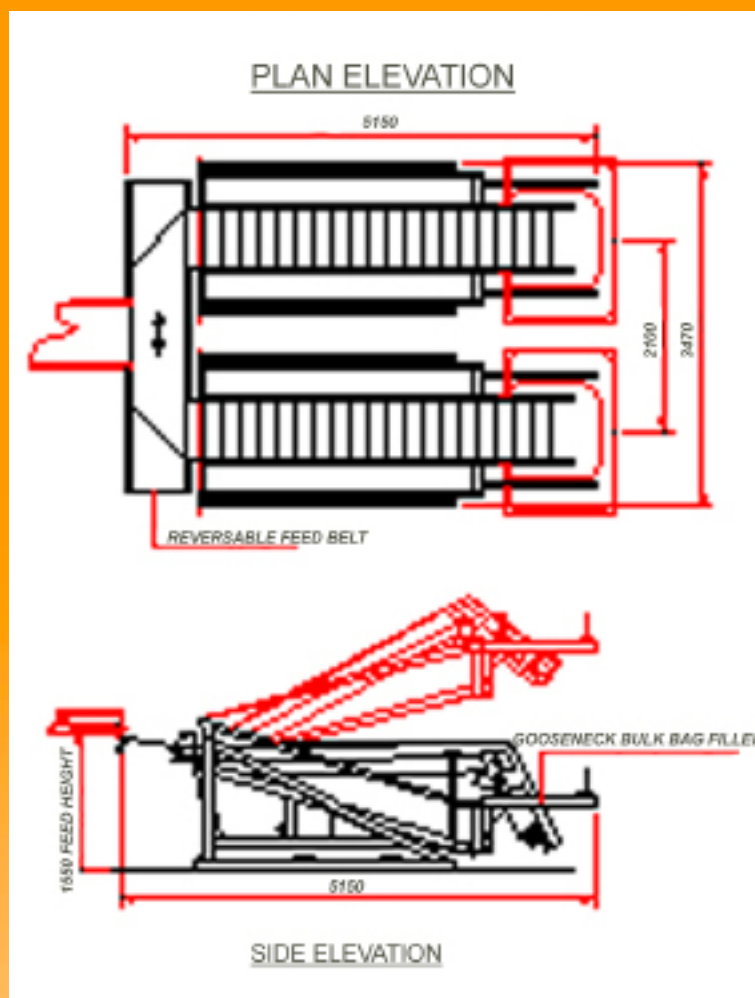

Features:

The Dual One Tonne Bag Filler is available in both manual and automatic versions. There is no need for an operator with the automatic model. As it fills the one tonne bags, the elevator raises automatically. Once the first bag is full, the reversable feed belt will change direction to commence filling the second bag, while the full bag is being replaced with a new one. The machine will lift the full bag off the floor to allow a pallet to be placed under it.

The elevator is of a 'gooseneck' nature so that the delivery of the product is as gentle as possible. The unit is controlled by a common hydraulic power pack and is easy to operate. All electrical wiring on the unit conforms to AS3000.

Special Features:

- Gentle "Gooseneck" delivery of product
- Low delivery height to bag
- Fully self-contained hydraulic system
- Simple fitting & removal of bags

Options:

- Automatic lift
- Variable speed elevator
- Electronic load cell weighing