

edp[®] Minibagger Crate Filler

Save time and money by using the edp[®] Semi-Automatic Crate Filler

e-as-y as...edp



- POTATOES - ONIONS - CITRUS -

With 60 years in the Fruit and Vegetables industry we have the expertise and experience to give you, our valued customer, the best and most reliable equipment economically possible



e-as-y as..



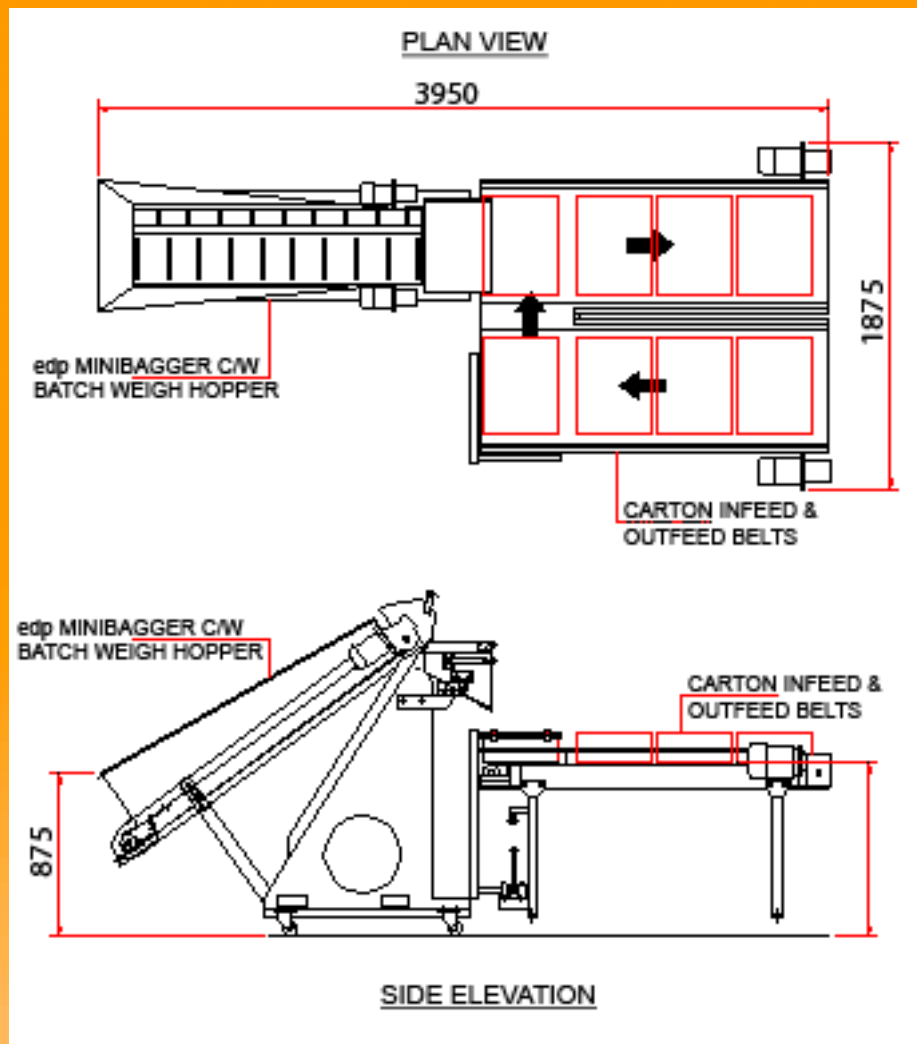

The **edp® Minibagger** has become very versatile. The hopper accumulates the pre-batched weighed product ready for discharge. An infeed and exit system automatically indexes crates or cartons for filling. This provides a totally automatic packaging solution. The minibagger's weight program can be altered in seconds, making this Minibagger exceptionally user friendly.

Every piece of edp® machinery and all consumables have been developed for maximum productivity; which gives you the benefits of saving time and money..

FEATURES:

- Electronic Weighing
- Electronic weight display
- Very economically priced
- 3 to 6 tonnes/hr capacity
- Three bag storage capacity (132lb/60kg)
- Fast Feed, trim feed belts (2 motors)
- 5kg to 20kg capacity filling

SPECIFICATIONS:

- Supply Voltage: 240 VAC / 10 AMP
- Air Consumption: 2 CFM @ 80 Psi

edp australia pty ltd, 33-37 O'Brien Street, Mooroopna, Vic 3629

Tel: +61 3 5820 5337, Fax: +61 3 5825 2758, email: sales@edp.com.au, <http://www.edp.com.au>