

# PLAN VIEW

15700

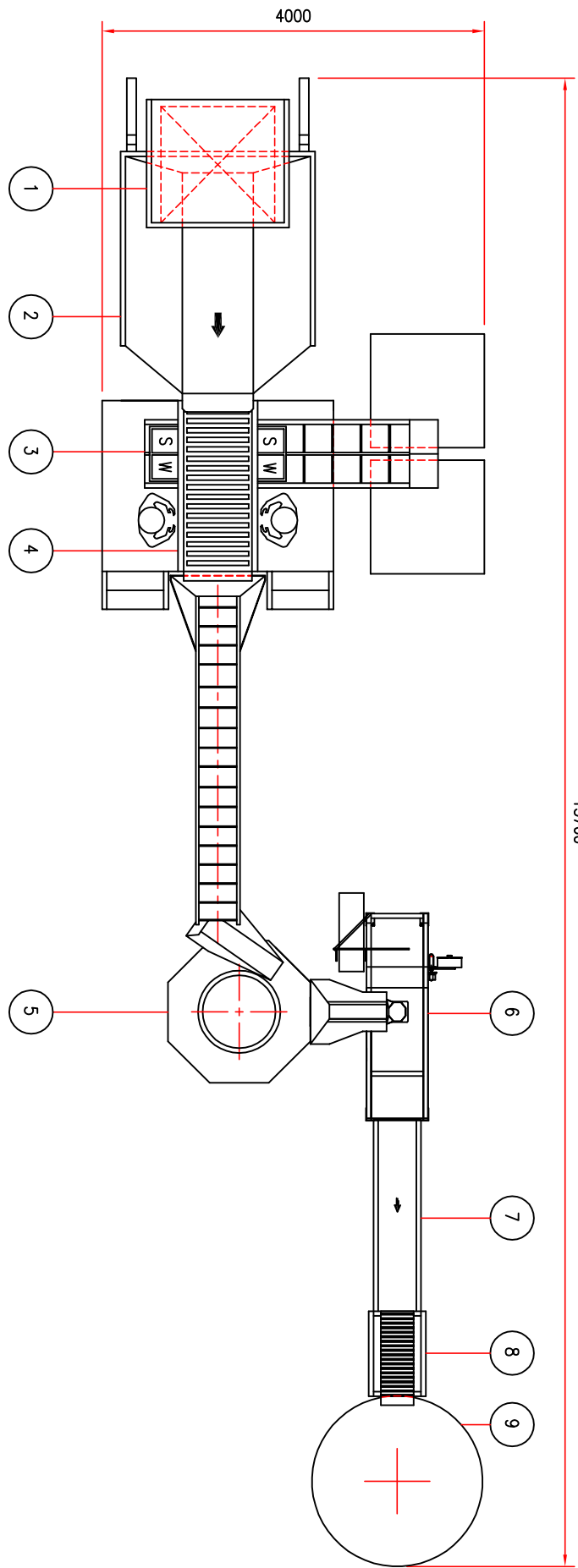

- 1 1/2t ELECTRIC BIN TIPPER
- 2 1t RECEIVAL HOPPER
- 3 600x2800 WASTE/SECONDS ELEVATOR
- 4 600x1800 ROLLER INSPECTION TABLE
- 5 PA25 COMBINATION WEIGHER
- 6 CB48 "D-PACK" BAGGING MACHINE
- 7 400mm WIDE PRE-PACK ELEVATOR
- 8 edp CHECKWEIGHER
- 9 Ø1800 ROTARY TABLE

## SAMPLE ONLY!

This design is the copyright of edp australia Pty. Ltd. and is submitted to you on the understanding that it is not to be used in any way without the written consent of edp australia Pty. Ltd. It is not to be used in any manner that may directly or indirectly breach any agreement between edp australia Pty. Ltd. and any third party. Acceptance of this drawing will be taken as an agreement to the above.

<b>edp australia Pty. Ltd.</b>		COPYRIGHT	
ONION PRE-PACK & FEED LINE		This design is the copyright of edp australia Pty. Ltd. and is submitted to you on the understanding that it is not to be used in any way without the written consent of edp australia Pty. Ltd. It is not to be used in any manner that may directly or indirectly breach any agreement between edp australia Pty. Ltd. and any third party. Acceptance of this drawing will be taken as an agreement to the above.	
REV NO	TITLE	DATE	DWG NO
001	ONION PRE-PACK & FEED LINE	4.10.2004	N37-000
SCALE	1:50	DATE	DWG NO
APPROVED	C.BURKE	4.10.2004	N37-000
SHEET NO		SHEET NO	